

B-B (1 : 1)

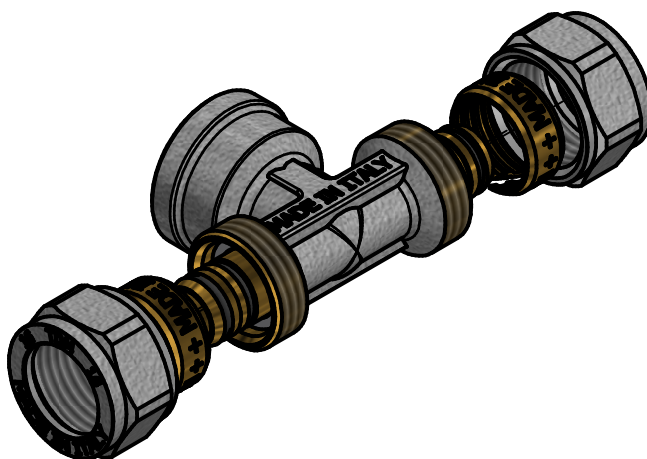
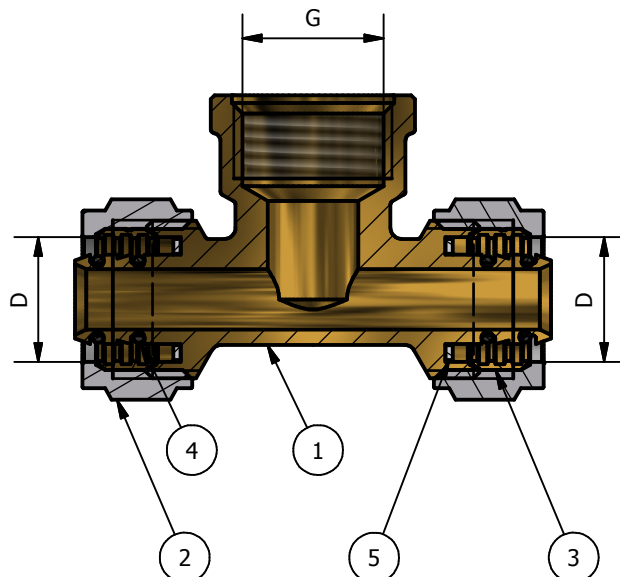
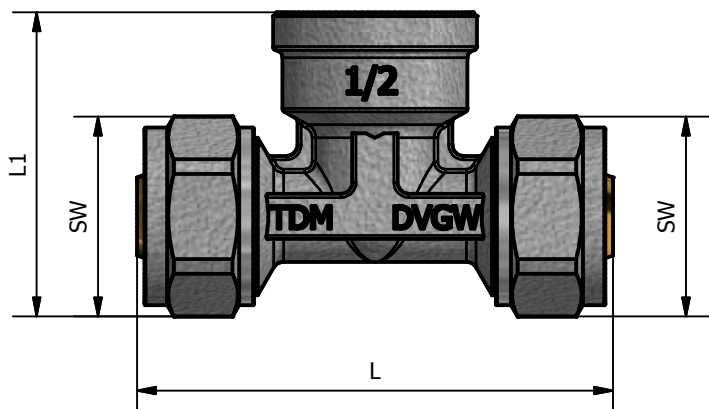

TDM CODE	SIZE	G	D	L	L1	SW
1055 1216	1/2x16	1/2	16	63	40	24
1055 1218	1/2x18	1/2	18	67	44	27
1055 1220	1/2x20	1/2	20	71	45	30
1055 3420	3/4x20	3/4	20	71	47,5	30
1055 3426	3/4x26	3/4	26	86	54	36
1055 0126	1"x26	1"	26	92	60	36
1055 0132	1"x32	1"	32	100	63	42

N°	DESCRIPTION	MATERIAL	CONFORMITY
1	BODY	CW 617N EN12165	1) DM 174 6 APRIL 2004
2	LOCKING NUT	CW 617N EN12165	2) UNI EN 10954-2
3	CUT RING	CW 614N EN12168	3) UNI EN 1254-3
4	O-RING	EPDM PEROX 681-1	4) UNI EN ISO 228-1
5	ISOLATOR	P.T.F.E.	

WORKING PRESSURE MAX	10 BAR
WORKING TEMPERATURE MIN-MAX	-20°C/110°C

00	Prima emissione	Delaini M.	27/02/2012
Rev.	Nota Revisione	Approvatore	Data Approvazione

Toll Gen: JS13	Stato sup.: Giallo Nichelato	Codice: 1055 scheda
Filetto: ISO 228	Note tecniche:	
Peso lavorato:	Peso grezzo:	N° stampo:
Descrizione: Female tee fitting		
Disegnatore: Delaini P.		Data: 27/02/2012
Materiale:		
TDM Brass s.r.l via Artigiani , 7-9 25030 Maclodio BS Italy tel +39 030 9972217 fax 030 9787089 www.tdmbrass.it email info@tdmbrass.it		