

C-C (1.5 : 1)

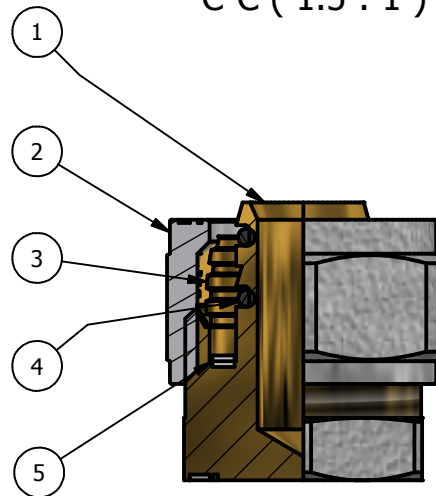
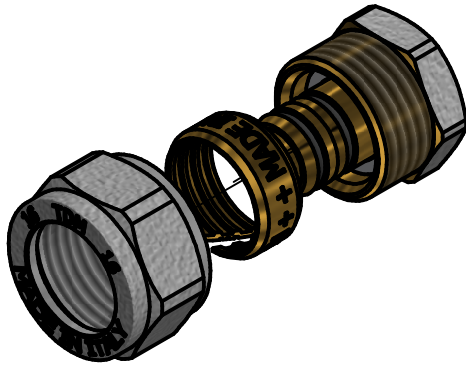

TDM Code	Size	D	L	SW	SW1
1020 16	16	∅16x2	25,5	21	24
1020 20	20	∅20x2	26,5	27	30

N°	DESCRIPTION	MATERIAL	CONFORMITY
1	BODY	CW 617N EN12165	1) DM 174 6 APRIL 2004
2	LOCKING NUT	CW 617N EN12165	2) UNI EN 10954-2
3	CUT RING	CW 614N EN12168	3) UNI EN 1254-3
4	O-RING	EPDM PEROX 681-1	4) UNI EN ISO 228-1
5	ISOLATOR	P.T.F.E.	

WORKING PRESSURE MAX	10 BAR
WORKING TEMPERATURE MIN-MAX	-20°C/110°C

00	Prima emissione	Delaini M.	15/01/2019
Rev.	Nota Revisione	Approvatore	Data Approvazione
Toll Gen:	JS14	Stato sup.:	Giallo Nichelato
Filetto:	ISO 228	Note tecniche:	
Peso lavorato:	Peso grezzo:	N° stampo:	
Materiale:		Disegnatore:	Data: 15/01/2019
		Delaini P.	
TDM Brass s.r.l via Artigiani , 7-9 25030 Maclodio BS Italy tel +39 030 9972217 fax 030 9787089 www.tdmbrass.it email info@tdmbrass.it			

Codice: 1020 scheda

Descrizione: Tappo femmina-End cup