

CANADA

CARATTERISTICHE TECNICHE

- Mobile coprilavatrice in kit
- Apertura con 2 ante
- Maniglie in resina
- Struttura in PVC estruso da 20 mm
- Staffa di fissaggio in ferro zincato regolabile
- Distanza studiata per la centrifuga
- Prodotto adatto per uso esterno

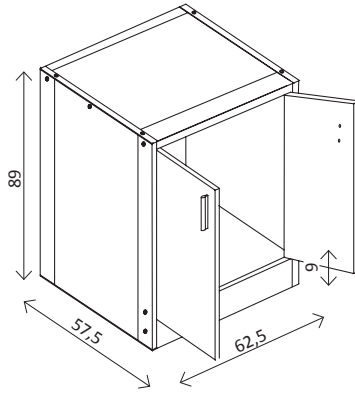

DIM. INT

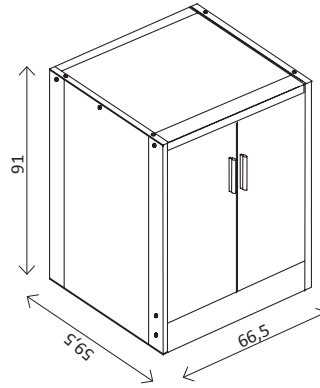

DIM. EST

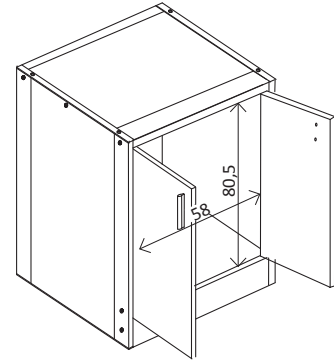

APERTURA / OPENING

